

W S K "P Z L - Ś W I D N I K" S.A.
Al. Lotników Polskich 1, 21-045 Świdnik, POLAND

SAILPLANE FLIGHT MANUAL

Model: **PW - 5 "SMYK"**

Serial No: **17.11.002**

Registration: **N77FZ**

Document No: **PW-5 / IWL / III / 97**

To be mandatory for sailplanes from S/N 17.07.010.

Date of issue: **March 17th. 1997.**

In Polish original pages identified by "Appr." are approved by Polish aviation authority:

**General Inspectorate of Civil Aviation
Civil Aircraft Inspection Board**

Seal:

Original date of approval:

This Manual should always be on board of the sailplane

This sailplane is to be operated in compliance with information and limitations contained herein.

The English translation has been made to the best of our knowledge and belief, but in case of uncertainty the Polish original is authoritative.

The English translation has been made by Wiesław Stafiej.



PW-5 "SMYK"
Sailplane Flight Manual

0.1 RECORD OF REVISIONS

Any revision of the present Manual, except actual weighing data, must be recorded in the following table and in case of approved Sections endorsed by the responsible airworthiness authority.

The new or amended text in the revised page will be indicated by a black vertical line in the left hand margin and the Revision No, and the date will be shown on the bottom left hand corner of the page.

| Rev. No | Affected Section | Affected pages | Date of issue | Approval | Date of approval | Date of insertion | Signature |
|-------------------|------------------|--------------------|---------------|----------|------------------|-------------------|-----------|
| 01 Sz1700.0938 | ----- | (i) (ii) 7.3 | 11.07.97 | | | | |

11.07.97

(i)



0.2 LIST OF EFFECTIVE PAGES

| Section | Page | Date of issue | Section | Page | Date of issue |
|---------|-----------|---------------|---------|----------|---------------|
| 0 | (i) | 11.07.97 | 5 | 5.1 | 17.03.97 |
| | (ii) | 11.07.97 | | Appr.5.2 | 17.03.97 |
| | (iii) | 17.03.97 | | Appr.5.3 | 17.03.97 |
| 1 | 1.1 | 17.03.97 | 6 | 5.4 | 17.03.97 |
| | 1.2 | 17.03.97 | | 6.1 | 17.03.97 |
| | 1.3 | 17.03.97 | | 6.2 | 17.03.97 |
| | 1.4 | 17.03.97 | | 6.3 | 17.03.97 |
| | 1.5 | 17.03.97 | | 7 | 7.1 |
| 2 | 2.1 | 17.03.97 | 7.2 | | 17.03.97 |
| | Appr.2.2 | 17.03.97 | 7.3 | | 11.07.97 |
| | Appr.2.3 | 17.03.97 | 7.4 | | 17.03.97 |
| | Appr.2.4 | 17.03.97 | 7.5 | | 17.03.97 |
| | Appr.2.5 | 17.03.97 | 8 | 8.1 | 17.03.97 |
| | Appr.2.6 | 17.03.97 | | 8.2 | 17.03.97 |
| | Appr.2.7 | 17.03.97 | | 8.3 | 17.03.97 |
| 3 | 3.1 | 17.03.97 | | 8.4 | 17.03.97 |
| | Appr.3.2 | 17.03.97 | 9 | 9.1 | 17.03.97 |
| 4 | 4.1 | 17.03.97 | | 9.2 | 17.03.97 |
| | Appr.4.2 | 17.03.97 | | | |
| | Appr.4.3 | 17.03.97 | | | |
| | Appr.4.4 | 17.03.97 | | | |
| | Appr.4.5 | 17.03.97 | | | |
| | Appr.4.6 | 17.03.97 | | | |
| | Appr.4.7 | 17.03.97 | | | |
| | Appr.4.8 | 17.03.97 | | | |
| | Appr.4.9 | 17.03.97 | | | |
| | Appr.4.10 | 17.03.97 | | | |
| | Appr.4.11 | 17.03.97 | | | |
| | Appr.4.12 | 17.03.97 | | | |



0.3 TABLE OF CONTENTS

| | Section |
|---|---------|
| <i>GENERAL</i> (a non-approved section) | 1 |
| <i>LIMITATIONS</i> (an approved section) | 2 |
| <i>EMERGENCY PROCEDURES</i> (an approved section) | 3 |
| <i>NORMAL PROCEDURES</i> (an approved section) | 4 |
| <i>PERFORMANCE</i> (a partly approved section) | 5 |
| <i>WEIGHT AND BALANCE</i> (a non-approved section) | 6 |
| <i>SAILPLANE AND SYSTEM DESCRIPTION</i> (a non-approved section) | 7 |
| <i>SAILPLANE HANDLING, CARE AND MAINTENANCE</i> (a non-approved section) | 8 |
| <i>SUPPLEMENTS</i> | 9 |



SECTION 1

GENERAL

- 1.1 INTRODUCTION
- 1.2 CERTIFICATION BASIS
- 1.3 WARNINGS, CAUTIONS AND NOTES
- 1.4 DESCRIPTIVE DATA
- 1.5 THREE-VIEW DRAWING
- 1.6 ABBREVIATIONS



PW-5 "SMYK"
Sailplane Flight Manual

1.1 INTRODUCTION

This Flight Manual has been prepared to provide pilots and instructors with the information for safe and efficient operation of PW-5 "Smyk" sailplane.

This Manual includes the material required by Joint Airworthiness Requirements JAR-22 and supplementary information supplied by the sailplane manufacturer.

1.2 CERTIFICATION BASIS

This type of sailplane has been approved by Civil Aircraft Inspection Board in accordance with Joint Airworthiness Requirements JAR-22 - issue of May 7th, 1987 with Change 4 and amendments: 22/90/1, 22/91/1.

The Type Certificate No **BG-194** has been issued on March 10th, 1994, category of airworthiness "U" (utility).

1.3 WARNINGS, CAUTIONS, NOTES

WARNING:

MEANS THAT THE NON-OBSERVATION OF THE CORRESPONDING PROCEDURE LEADS TO AN IMMEDIATE OR IMPORTANT DEGRADATION OF THE FLIGHT SAFETY

CAUTION:

MEANS THAT THE NON-OBSERVATION OF THE CORRESPONDING PROCEDURE LEADS TO A MINOR OR TO A MORE OR LESS LONG TERM DEGRADATION OF THE FLIGHT SAFETY

NOTE:

Draws the attention on any special item not directly related to safety, but which is important or unusual.



1.4 DESCRIPTIVE DATA

SAILPLANE DESCRIPTION

PW-5 "Smyk" is the single-seat sailplane with the cantilever mid-wing and standard tailplane arrangement. The structure is all glass-epoxy composite.

The wings of trapeze contour with bow-shaped ends. The wings are of monospar structure with sandwich shells.

The plate air brake extended on the upper wing surface only.

The fuselage shells are of monocoque structure, stiffened with frames.

Rudder is fabric covered.

The cockpit is equipped with in flight adjustable pedals and back rest adjustable on ground. The canopy opens forwards.

The fixed undercarriage contains of the main wheel with shock absorber and drum brake, front wheel and tail skid with small wheel.

Two take-off hooks are installed (nose hook for aerotowing and C.G. hook for winch-launching).

BASIC DATA

| | |
|---------------------------|------------------------|
| wing span | 13.44 m |
| length | 6.22 m |
| height | 1.86 m |
| wing area..... | 10.16 m ² |
| aspect ratio | 17.8 |
| wing loading | 29.5 kg/m ² |
| Mean Standard Chord | 0.798 m |



1.5 THREE-VIEW DRAWING

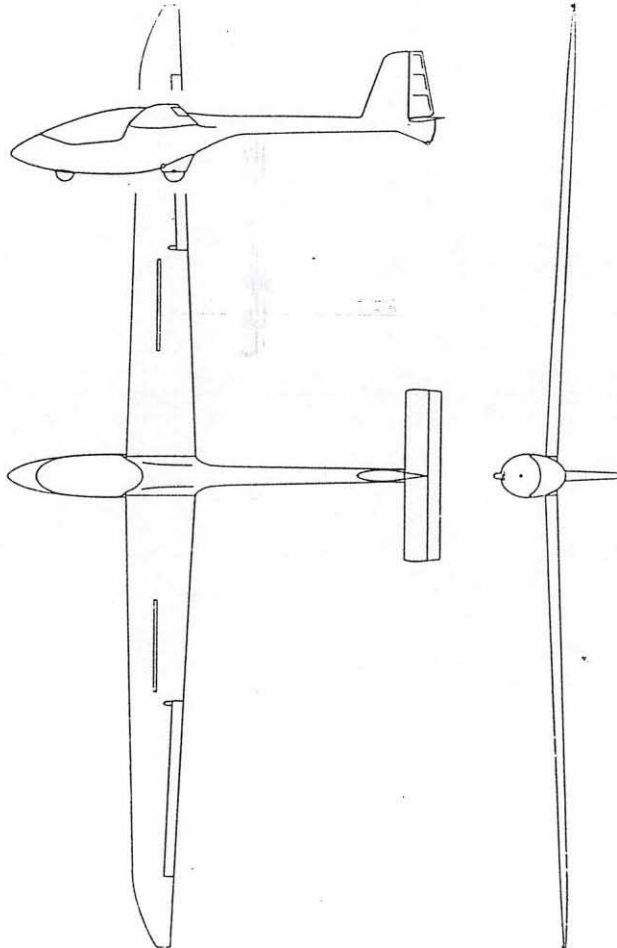

PW-5 "Smyk" sailplane
Fig. 1 - 1



1.6 ABBREVIATIONS

- CAS - calibrated airspeed means indicated airspeed of a sailplane, corrected for position (due to position of pressure ports on sailplane) and instrument error. Calibrated airspeed is equal to true airspeed in standard atmosphere at sea level.
- C.G. - centre of gravity.
- daN - decanewton.
- h - hour.
- IAS - indicated airspeed means the speed of a sailplane as shown on its pitot - static airspeed indicator uncorrected for airspeed indicator system error. In this Manual zero instrument error is assumed.
- m - meter.
- ft - feet
- kg - kilogram.
- kts - knots
- s - second.
- V_{S1} - means the stall speed or the minimum steady flight speed obtained in a specific configuration.



SECTION 2

LIMITATIONS

- 2.1 INTRODUCTION
- 2.2 AIRSPEED
- 2.3 AIRSPEED INDICATOR MARKINGS
- 2.4 WEIGHT
- 2.5 CENTRE OF GRAVITY
- 2.6 APPROVED MANOEUVRES
- 2.7 MANOEUVRING LOAD FACTORS
- 2.8 KINDS OF OPERATIONS
- 2.9 MINIMUM EQUIPMENT
- 2.10 AEROTOW AND WINCH-LAUNCHING
- 2.11 OTHER LIMITATIONS
- 2.12 LIMITATIONS PLACARDS



PW-5 "SMYK"
Sailplane Flight Manual

2.1 INTRODUCTION

Section 2 includes operating limitations, air speed indicator markings, limitations placards necessary for safe operation of the sailplane. The limitations included in this Section and in Section 9 have been approved by Civil Aircraft Inspection Board.

2.2 AIRSPEED

Airspeed limitations and their operational significance are shown below:

| | Speed | kts IAS | Remarks |
|----------|-------------------------------|--------------------|--|
| V_{NE} | Never exceed speed | 115 | Do not exceed this speed in any operation and do not use more than 1/3 of control deflection |
| V_{RA} | Rough air speed | 81 | Do not exceed this speed except in smooth air and then only with caution. Examples of rough air are: lee-wave rotor, thunderclouds, etc. |
| V_A | Manoeuvring speed | 81 | Do not make full or abrupt control movement above this speed, because under certain conditions the sailplane may be overstressed by full control movement. |
| V_W | Maximum winch launching speed | 65 | Do not exceed this speed during winch-launching. |
| V_T | Maximum aerotowing speed | 81 (CAS =80) | Do not exceed this speed during aerotowing. |



2.3 AIR SPEED INDICATOR MARKINGS

Airspeed indicator markings and their colour-code significance are shown below:

| Marking | kts IAS value or range | Significance |
|-----------------|------------------------|---|
| Green arc | 38 - 81 | <i>Normal operating range.</i> (Lower limit is 1.1 V_{S1} at maximum weight and front limit C.G. location. The upper limit is the rough air speed). |
| Yellow arc | 81-115 | Manœuvres must be conducted with caution and only in smooth air. |
| Red line | 115 | Maximum speed for all operations. |
| Yellow triangle | 51 | Approach speed at maximum weight. |



2.4 WEIGHT

| | |
|---|--------|
| maximum weight | 300 kg |
| maximum fuselage and tailplane weight | 112 kg |
| maximum load in luggage compartment..... | 5 kg |

2.5 CENTRE OF GRAVITY

Centre of Gravity range for flight:

| | |
|---------------|---|
| - front limit | 20% of Mean Standard Chord 23.5 cm aft of root chord leading edge |
| - rear limit | 42% of Mean Standard Chord 41.0 cm aft of root chord leading edge. |

The way of C.G. location finding and the C.G. location range for empty sailplane are described in MAINTENANCE MANUAL.

WARNING:

THE SAILPLANE MAY BE SAFETY OPERATED ONLY WHEN LOADED IN RANGE DEFINED IN SECTION 6 OF THIS MANUAL.

2.6 APPROVED MANOEUVRES

This sailplane is certified in the Utility Category.

The following manoeuvres are allowed :

- looping,
- stall turn,
- spinning,
- spiral.

Performing technique and recommended entry speeds are contained in Section 4 of this Manual.

Apr. 2.4



2.7. MANOEUVRING LOAD FACTORS

Limit load factors are :

- for V_A = 81 kts airspeed +5.3 / -2.65
- for V_{NE} = 115 kts airspeed +4.0 / -1.5

2.8 KINDS OF OPERATION

- day flying,
- cloud flying,
- aerobatic manoeuvres (according to item 2.6 of this Manual).

2.9 MINIMUM EQUIPMENT

- 4 pieces pilot's belts,
- airspeed indicator (marked per item 2.3 of this Manual),
- altimeter,
- total energy variometer,
- variometer,
- magnetic compass,
- side-slip and turn indicator,
- transceiver,
- power supply.

CAUTION:

DURING THE FLIGHT PILOT MUST HAVE BACK PARACHUTE ATTACHED.



2.10 AEROTOW AND WINCH - LAUNCHING

AEROTOW

The hook for aerotowing (nose hook) is located before the front wheel.

- maximum aerotowing airspeed $V_T = 81$ kts
(CAS = 80 kts)
- maximum force damaging the towing cable or safety link 700 daN
- minimum towing cable length 20 m

WARNING:

THE AEROTOWING WHEN USING THE C.G. HOOK IS NOT PERMITTED.

WINCH-LAUNCHING

The hook for winch-launching (C.G. hook with automatic release) is located before the main wheel on the left side of fuselage.

CAUTION:

THE WINCH-LAUNCHING WHEN USING THE FRONT HOOK IS NOT PERMITTED.

- maximum winch-launching speed $V_w = 65$ kts
- maximum force damaging the cable or safety link 700 daN

2.11 OTHER LIMITATIONS

- 1) Flying in known icing conditions is not permitted.
- 2) Night flying is not permitted.
- 3) Aerobatic manoeuvres in rough air are prohibited.
- 4) The pilots of body + parachute weight of below 60 kg must have the front limit location of the back rest.
- 5) The flights on the altitude of above 16400 ft are prohibited.



2.12 LIMITATIONS PLACARDS

| | |
|---|----------------|
| Maximum winch-launching speed | $V_W = 65$ kts |
| Maximum aerotowing speed..... | $V_T = 81$ kts |
| Manoeuvring airspeed..... | $V_A = 81$ kts |
| Allowed manoeuvres: looping, stall turn, spinning, spiral | |

| | |
|---|------------|
| Empty sailplane weight | max.190 kg |
| Maximum weight | 300 kg |
| Maximum cockpit load | 110 kg |
| Minimum pilot's + parachute weight | 55 kg |
| Maximum force damaging the towing cable or safety link..... | 700 daN |

WARNING:

**PILOTS OF BODY + PARACHUTE WEIGHT OF BELOW 60
KG MUST HAVE THE BACK-REST AT FRONT LIMIT
LOCATION.**

luggage max. 5 kg

The other placards are shown in Section 7.

Location of the placards is described in MAINTENANCE MANUAL.



SECTION 3

EMERGENCY PROCEDURES

- 3.1 INTRODUCTION
- 3.2 CANOPY JETTISON
- 3.3 BAILING OUT
- 3.4 STALL RECOVERY
- 3.5 SPIN RECOVERY
- 3.6 SPIRAL DIVE RECOVERY



3.1 INTRODUCTION

Section 3 provides the procedures in emergency conditions

3.2. CANOPY JETTISON

- 1) Pull the canopy emergency jettison handle full.
- 2) Catch the canopy locks hand-grips and push the canopy strongly forward off.

3.3. BAILING OUT

- 1) Jettison the canopy.
- 2) Release the safety belts.
- 3) Bail out of the sailplane (if the sailplane rotates bail out towards the rotation).

3.4 STALL RECOVERY

Release the control stick.

3.5 SPIN RECOVERY

- 1) Check ailerons neutral.
- 2) Apply full rudder opposite to the direction of the spin.
- 3) Ease the stick forward until rotation ceases.
- 4) Centralise rudder and ease out of the ensuing dive.

3.6 SPIRAL DIVE RECOVERY

- 1) Cancel the bank with the co-ordinated aileron and rudder deflection.
- 2) Recover the sailplane out of the dive.



SECTION 4

NORMAL PROCEDURES

- 4.1 INTRODUCTION
- 4.2 RIGGING AND DE-RIGGING
- 4.3 PRE-FLIGHT INSPECTION
- 4.4 INSPECTION BEFORE TAKE-OFF
- 4.5 NORMAL PROCEDURES AND RECOMMENDED SPEEDS
 - 4.5.1 PROCEDURES BEFORE TAKE-OFF
 - 4.5.2 TAKE-OFF
 - 4.5.3 FLIGHT
 - 4.5.4 APPROACH
 - 4.5.5 LANDING
 - 4.5.6 FLIGHT RAIN
 - 4.5.7 AEROBATICS
- 4.6 PROCEDURES AFTER FLIGHTS



4.1 INTRODUCTION

Section 4 provides the procedures of normal sailplane operation.

The normal procedures associated with additional equipment can be found in Section 9.

4.2 RIGGING AND DE-RIGGING

- A) Rigging team: 2 persons (or 3 persons without the rigging jigs).
- B) Rigging jigs: fuselage support, wing tip support (of about 1.2 m height).
- C) Sequence of rigging procedures:
 1. clean and grease all the assembling fittings, bolts and control system connections,
 2. put the fuselage on the support (in case no support is in disposition one person holds the fuselage), open the canopy, put the airbrake cockpit lever backwards, open the inspection hole on the fuselage,
 3. assemble the right-hand wing first. Insert the spar end into the fuselage. Fit together the wing and fuselage fittings. insert the right-hand main bolt to 1/2" location (bolt lever locate in the grip) then insert the left-hand main bolt into "1/2" location too (as above) - insert the right-hand rear bolt till to stop-(see Fig. 4-2),

CAUTION:

THE BOLTS SHALL BE INSERTED BY HAND ONLY, NO TOOL ALLOWED. IN CASE OF JAMMING (EXCESSIVE DRAG) BREAK THE RIGGING AND CHECK THE BOLTS FOR CORRECT CLEANING.

4. support the wing tip (in case of having no support one person should hold the wing),
5. rigging of the left-hand wing: insert the spar end into the fuselage. fit together the wing and fuselage fittings, insert the rear bolt till to stop, insert the left-hand main bolt till to securing it with the latch- then insert the right-hand main bolt in the same manner,
6. connect the control systems of aileron and air brake (see Fig. 4 -1),

Appr. 4.2



7. rigging of the tailplane: deflect the rudder till to stop, fit the tailplane to fuselage (the stabiliser front pins must engage the fuselage fittings), insert the rear bolt (placing the latch in lower position) till to securing with the latch. The elevator control circuit is connected automatically, (see Fig. 4 -3),
8. check securing of the main bolts of wings and rear bolt of tailplane and connection of control systems, close the inspection hole on the fuselage.

De-rigging requires the inverted sequence.

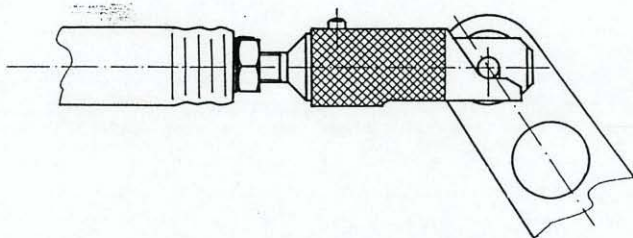

A) The connected and secured end

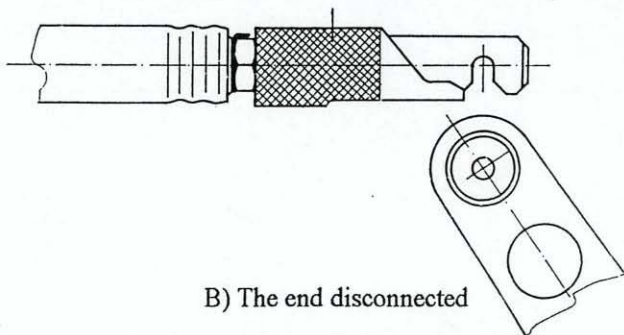

B) The end disconnected

Connection of control system of aileron and air brake with disconnectable ends.

Fig. 4 - 1

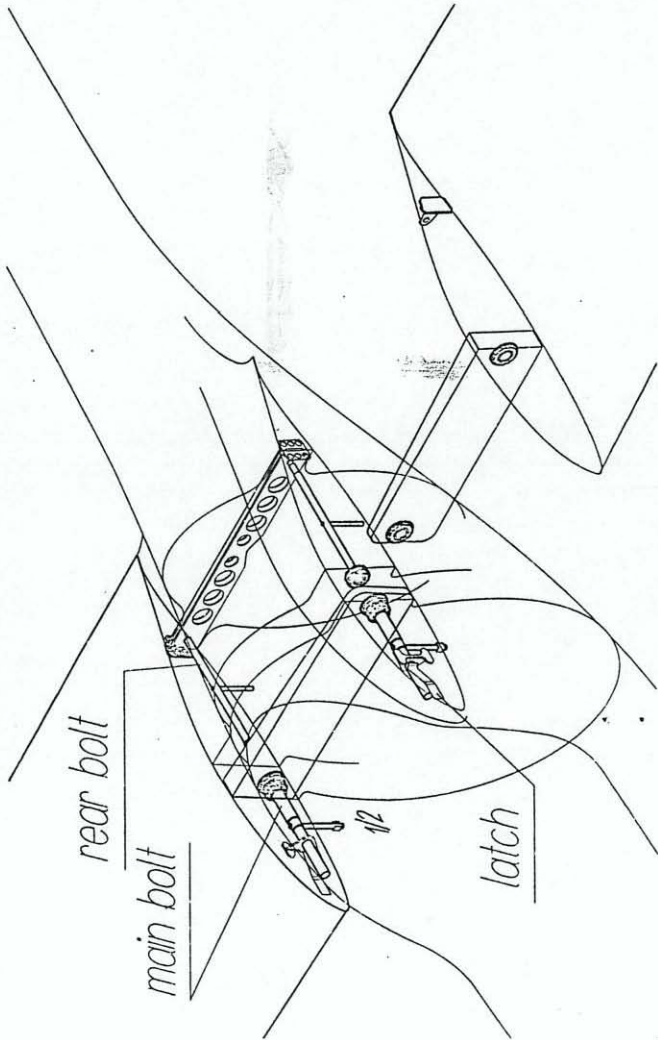

Rigging the wings
Fig. 4 - 2

Appr. 4.4



PW-5 "SMYK"
Sailplane Flight Manual

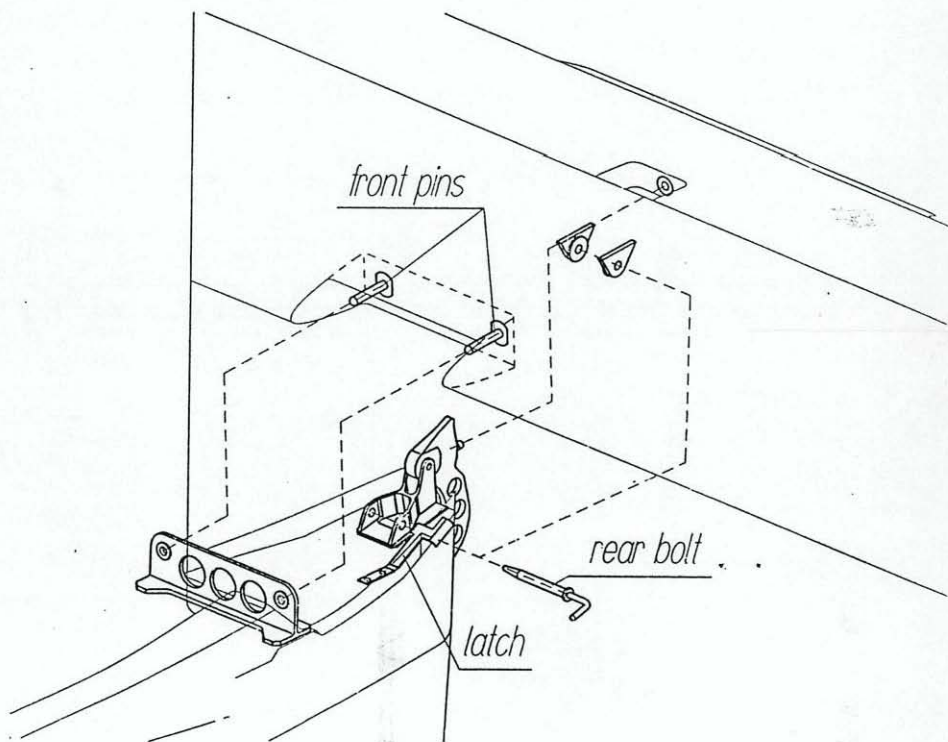

Rigging the tailplane
Fig. 4 - 3

Appr. 4.5



4.3 PRE - FLIGHT INSPECTION

NOTE:

Before the flight the validity of Airworthiness Certificate and the updating of periodic inspections should be checked.

The pre-flight inspection and after every rigging inspection are recommended to be performed according to the diagram (see Fig. 4 - 4):

1. - check the fuselage front part, surface condition, the pressure ports being not obscured,
2. - check the condition of perspex surface, open the canopy,
 - check the wing connection bolts to be inserted and secured,
 - check the instruments and installation connection,
 - check the correct operation of the elevator, rudder and ailerons, maximum deflections, plays and friction,
 - check the correct operation of air brake - the maximum extended position and locking in the retracted position,
 - check the operation of trimming device,
 - check the operation of front and C.G. take-off hooks,
 - check the cockpit for the moveable items - remove,
 - check the opening and locking of the canopy,
 - check the safety belts, pilot's back-rest, seat pillow,
3. - check the condition and pressure in pneumatics,
 - check the rollability of the wheels,
 - check the operation of wheel brake and shock absorber,
4. - inspect the upper and lower wing surface as well as leading and trailing edges,
 - check the ailerons, surface condition, suspension, plays, deflections, friction,
 - check the air brake, condition, plays, extending, retracting, fitting the caps into the contour,
5. - check the connection of control systems of aileron and brake,



PW-5 "SMYK"
Sailplane Flight Manual

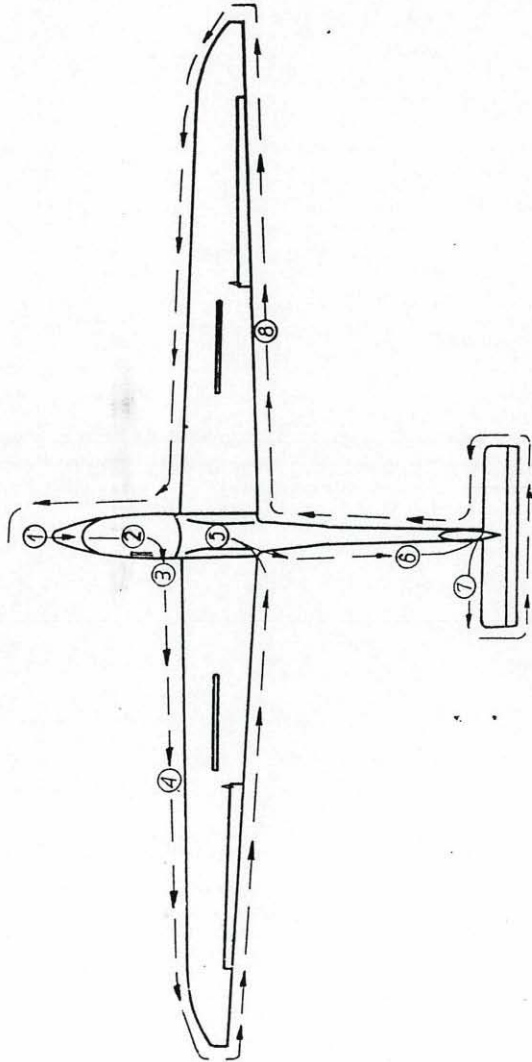

Pre - flight inspection
Fig. 4 - 4

Appr. 4.7



6. - check the fuselage rear part, especially bottom part and tail skid,
 - check the fin, surface condition,
 - check the rudder for fabric covering damages, upper hinge and cable fitting securing,
7. - check the tailplane, fitting, securing, surface condition,
 - check the elevator deflections, plays, friction,
8. - as in item 4.

4.4 INSPECTION BEFORE TAKE-OFF

- check the fastening bolts to be in position and secured,
- check the tailplane for the correct rigging and securing,
- open the inspection hole and check the aileron and air brake control system ends for correct connection and securing,
- check the correct operation of control surfaces and air brake namely without jamming, excessive play and that they have the full movements.

4.5 NORMAL PROCEDURES AND RECOMMENDED SPEEDS

4.5.1 PROCEDURES BEFORE TAKE-OFF

- check and put on the parachute,
- adjust the pilot's back-rest,
- take place in the cockpit,
- fasten and tighten the belts,
- adjust the pedals,
- make the full movements of control surfaces, pull the towing cable release handle, extend and retract the air brake,
- check the transceiver operation,
- check the altimeter setting,
- close and lock canopy.



4.5.2 TAKE-OFF

A) AEROTOWING

Before take-off put the trimming device handle into 1-2 position for the light pilot and up to 5-6 position for the heavy pilot.

Roll on the main wheel.

The controlling behaviours in towed flight are the typical ones.

The sailplane can be trimmed in the whole airspeed range in towed flight.

The flying under the towing airplane downwash is not recommended since the towing cable rubs the fuselage front part.

Recommended aerotowing airspeeds:

- at climbing 60 kts
- at cross-country towing 81 kts

B) WINCH-LAUNCHING

Before take-off put the trimming device handle into position 1 for the light pilot up to 5-6 position for the heavy pilot.

Due to the hook location it is recommended the launching cable position at the left-hand side of the sailplane.

If however the cable is situated clearly at the right-hand side of the sailplane it should not be positioned on the left side of the front wheel.

During the ground run the stick should not be pulled excessively to avoid the tail skid impact onto the ground. Roll on the main wheel.

During the steep climb the stick forces are of small value.

The best launching airspeed is 49 -54 kts.

RELEASING

The sailplane is equipped with the self-releasing hook.

Two releasing techniques exist:

- 1) before the intended releasing release the stick to lower the cable tension then pull the releasing handle in the cockpit.
- 2) before the intended releasing hold the stick in position till the self-releasing occurs. After releasing recover immediately the glide and check the cable releasing pulling the control handle.



4.5.3 FLIGHT

CIRCLING

The circling airspeed, depending on the bank angle and sailplane weight ranges 43 -46 kts.

The bank reversal 45°/45° requires 3.5 seconds.

SIDE SLIP

The sideslip should be performed at the airspeed of 49 kts or higher. Up to 20° bank the sailplane allows to retain the heading. For the greater bank the sailplane turns. With air brake retracted as well as with extended the sideslip is a typical one. The airspeed indicator records in sideslip are not valid.

AIR BRAKE OPERATION

For the airbrake full extended the sailplane ratio in approach is 6.5. The diving at 45° in respect to the horizon with air brake full extended does not exceed 115 kts airspeed. The extending or retracting of the air brake creates no pitch. The air brake may be extended in the whole airspeed range. The retraction requires the airspeed of below 81 kts.

NOTE:

When extending the airbrake at the airspeed above 92 kts the considerable negative vertical acceleration appears. Therefore the air brake should be extended gently. The pilot should be tightened with the belts.

4.5.4 APPROACH

Recommended approach airspeed is 51 kts.

The approach angle should be adjusted by means of air brake.

4.5.5 LANDING

Touch ground with the main wheel. Avoid the tail skid ground impact. Ground run should employ the front wheel to allow for direction retaining and efficient braking.



4.5.6 FLIGHT IN RAIN

No abnormal control characteristics when flying in rain appear. No significant increase of stalling speed observed.

4.5.7 AEROBATICS

Before the initiation of the manoeuvres the sailplane should be trimmed for about 70 kts airspeed. Check the air brake to be locked and check the absence of moveable items in the cockpit.

Manoeuvres are performed in the typical way.

The recommended entry (recovery) speeds and load factors gained are listed below:

| Manoeuvre | entry speed (IAS) kts | load factors |
|------------|-----------------------|--------------|
| looping | 92 to 97 | 3.4 g |
| stall turn | 97 | 3.2 g |
| spinning | 81 (recovery) | 4.0 g |
| spiral | 65 | 3.5 - 4.0 g |

SAILPLANE BEHAVIOURS IN SPINNING

| pilot with parachute | light 55 - 70 kg | mean 70 - 90 kg | heavy above 90 kg |
|---------------------------------|--------------------------|-----------------------------|---------------------------|
| aileron deflection | arbitrary | neutral or towards rotation | only towards rotation |
| longitudinal oscillations | exist considerable | exist | not exist |
| angle in respect to the horizon | 40 - 50 deg. | 50 deg. | ^A 60 - 70 deg. |
| delay in recovery | no more than 3/4 of turn | no more than 1/4 of turn | without delay |

The recovery is typical one (see item 3.5).



4.6 PROCEDURES AFTER FLIGHTS

- switch-off the electrical devices,
- drain, if necessary, the ducts of total and static pressure installations (acc. to MAINTENANCE MANUAL),
- clean the pilot's cockpit and the whole sailplane,
- perform the inspection same as the pre-flight one.



SECTION 5

PERFORMANCE

- 5.1 INTRODUCTION**
- 5.2 APPROVED DATA**
 - 5.2.1 AIRSPEED INDICATOR SYSTEM CALIBRATION
 - 5.2.2 STALL SPEED (IAS)
- 5.3 NON-APPROVED FURTHER INFORMATION**
 - 5.3.1 DEMONSTRATED CROSSWIND PERFORMANCE
 - 5.3.2 FLIGHT POLAR



5.1 INTRODUCTION

Section 5 provides approved data for airspeed calibration, stall speeds and additional non-approved information.

The data are calculated on the base of actual flight test results gained on the sailplane of good condition and using the average controlling techniques.

5.2 APPROVED DATA

5.2.1 AIRSPEED INDICATOR SYSTEM CALIBRATION

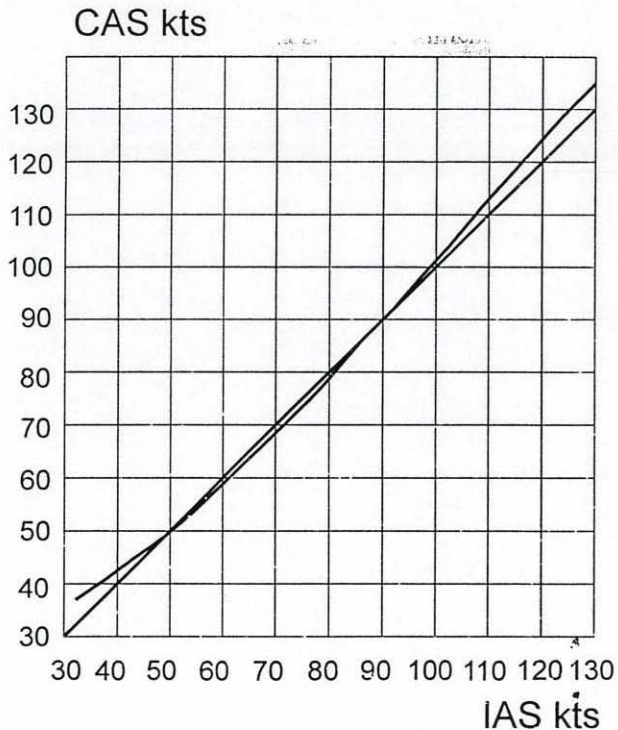

Airspeed indicator system calibration

Fig. 5 - 1



5.2.2 STALL SPEEDS (IAS)

SAILPLANE WITH HEAVY PILOT

The sailplane with heavy pilot (above 90 kg) does not stall in straight flight with air brake extended as well as retracted.

The flight with the stick pulled full is possible with the minimum airspeed of about 30 - 35 kts. With the air brake extended the minimum airspeed ranges about 33 - 38 kts.

When circling with 45° bank the sailplane does not stall either. The minimum airspeed ranges about 36 - 38 kts. With the air brake extended the minimum airspeed ranges about 39 - 41 kts.

SAILPLANE WITH MEAN OR LIGHT PILOT

The sailplane with mean or light pilot (55-90 kg) stalls in straight flight gently and it is possible to retain the lateral balance.

The stall warning is mild. When stalled the sailplane drops down very gently and symmetrically. When pulling the stick more no tendency to wing dropping appears. The stalling speed ranges about 26-31 kts. With the air brake extended the stalling speed ranges about 30-36 kts.

When circling with 45° bank as the critical airspeed is gained the sailplane automatically recovers the wings to level position or gently banks towards the turn. The slight releasing of the stick or the aileron deflection associated with the stick releasing results the transition to the normal flight without the tendency to spinning. The stalling speed ranges about 30-36 kts. With the air brake extended the stalling speed ranges about 36-39 kts.

The altitude loss during recovery is not more than 98 ft.

5.3 NON-APPROVED FURTHER INFORMATION

5.3.1 DEMONSTRATED CROSSWIND PERFORMANCE

The demonstrated crosswind component at take-off and landing is 12 kts.

During the take-off or landing ground run on two wheels the sailplane is practically non-sensitive to the crosswind action.



5.3.2 FLIGHT POLAR

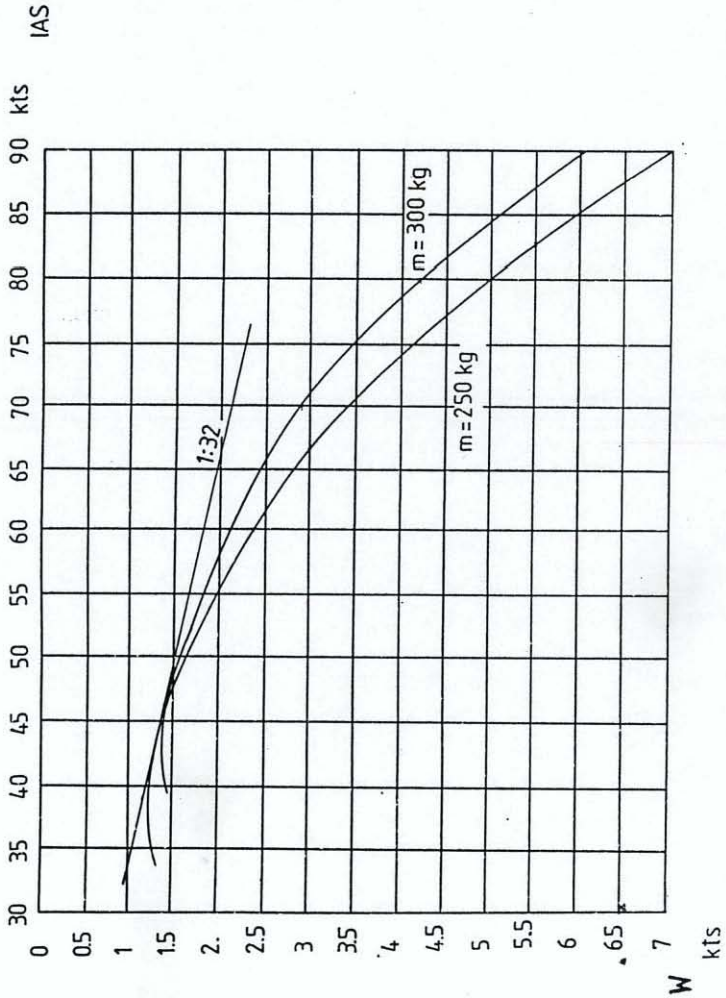

Flight polar
Fig. 5 - 2



SECTION 6

WEIGHT AND BALANCE

- 6.1 INTRODUCTION
- 6.2 PERMITTED PAYLOAD RANGE AND WEIGHT AND BALANCE RECORD



6.1 INTRODUCTION

This Section contains the payload range within which the sailplane may be safely operated.

The weighing and C.G. location calculation procedure as well as the range of weight and C.G. locations of empty sailplane are contained in MAINTENANCE MANUAL.

Comprehensive list of all equipment available for this sailplane and the installed equipment during the weighting of the sailplane is contained in MAINTENANCE MANUAL.

6.2 PERMITTED PAYLOAD RANGE AND WEIGHT AND BALANCE RECORD

PERMITTED PAYLOAD RANGE

Maximum cockpit load (pilot + parachute + luggage).....110 kg
Minimum pilot's weight with parachute.....55 kg

CAUTION:

**PILOTS OF THE BODY+PARACHUTE WEIGHT BELOW
60 KG MUST HAVE THE BACK-REST LOCATED IN LIMIT
FRONT POSITION**



SECTION 7

SAILPLANE AND SYSTEMS DESCRIPTION

- 7.1 INTRODUCTION
- 7.2 COCKPIT DEVICES
- 7.3 LUGGAGE COMPARTMENT
- 7.4 INFORMATION PLACARDS IN COCKPIT



7.1 INTRODUCTION

This Section provides description and operation of the cockpit devices. The particular data on the additional or other than standard devices are contained in Section 9 of this Manual.

The detailed description of the sailplane and its systems is contained in MAINTENANCE MANUAL.

7.2 COCKPIT DEVICES

Description for Fig. 7 - 1:

- 1) instrument panel,
- 2) towing cable releasing hand-grip (yellow) - pull to release,
- 3) pedal adjusting hand grip (brown on the instrument panel pedestal) - to adjust the pedals:
 - unlock the pedals pulling the hand-grip,
 - locate the pedals into the required position by pushing or pulling the feet,
 - release the hand-grip,
 - check the locking by pushing the pedals with feet.
- 4) canopy emergency jettisoning hand-grip (red) - pull to jettison the canopy,
- 5) air brake control lever (blue)- operation of air brake control:
 - extension - backwards,
 - retraction - forwards,
 - locking of the air brake in retracted position - press the lever forwards till clearly perceptible locking click appears,
 - unlocking of the air brake - pull the control lever backwards till the clearly perceptible unlocking click appears.
- 6) wheel brake lever -
to brake the wheel press the wheel brake lever to the air brake lever,



- 7) trimming device ball-grip (green) - sailplane trimming:
 - unlock the device pressing down the ball-grip,
 - locate the ball in one of 11 locations (moved forward - the airspeed increases, moved backward - the airspeed decreases),
 - lock the device by means of releasing the pressing on the ball,
 - check the locking by moving the ball forwards or backwards,
- 8) ventilation hand -grip - pull the hand-grip to open the air intake,
- 01 | 9) canopy locks hand-grips (white and red)- operation of locks:
 - forwards - canopy opened,
 - backwards till to perceptible lock - canopy locked,
- 10) pilot's belts,
- 11) pilot's back-rest - the back-rest is adjusted by means of:
 - location of back-rest lower fitting in one of 5 openings in the seat plan,
 - inserting under the back-rest the suitable amount of adjusting inserts (item 12),
- 12) pilot's back rest adjusting inserts,
- 13) sanitary equipment cover,
- 14) seat pillow,
- 15) push-to-talk button,
- 16) turn indicator switch, positions: I -on , O - off,
- 17) microphone,
- 18) loudspeaker
- 19) container for First Aid Kit

7.3 LUGGAGE COMPARTMENT

The luggage compartment is located behind the pilot's back-rest. It is provided for barograph or other items.

Inside the compartment 4 fixing points are provided for strips fastening the luggage.

Maximum luggage weight is 5 kg.



PW-5 "SMYK"
Sailplane Flight Manual

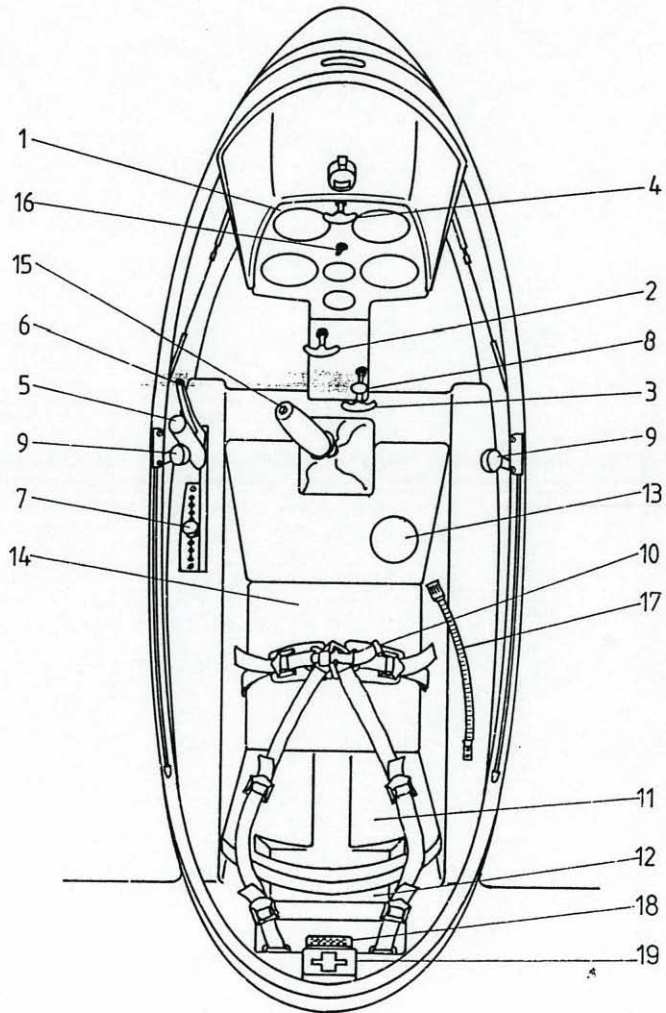

Cockpit devices
Fig. 7 - 1



7.4 INFORMATION PLACARDS IN COCKPIT

The operation limitations placards are described in Section 2. Rigging and de-rigging placards and location of the placards are described in MAINTENANCE MANUAL.

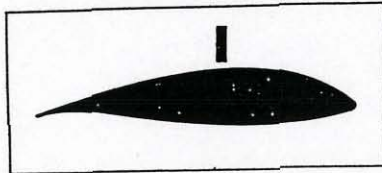

air brake

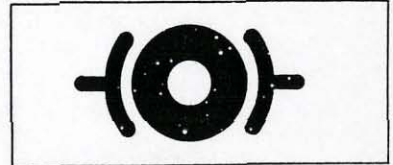

wheel brake



back-rest adjustment

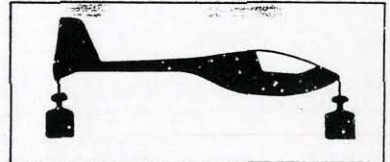

trimming device



cable releasing



pedal adjustment

11 · 9 · 7 · 5 · 3 · 1

location of trimming device



canopy locks



cockpit ventilation



canopy jettison

Information placards in cockpit

Fig. 7 - 2



SECTION 8

**SAILPLANE HANDLING, CARE AND
MAINTENANCE**

- 8.1 INTRODUCTION**
- 8.2 SAILPLANE INSPECTION PERIODS**
- 8.3 SAILPLANE ALTERATIONS OR REPAIRS**
- 8.4 GROUND HANDLING, ROAD TRANSPORTATION**
- 8.5 CLEANING AND STORING**



8.1 INTRODUCTION

This Section contains manufacturer's recommended procedures for proper ground handling of the sailplane. It also identifies the inspection and ground handling requirements, which must be followed to retain the performance and condition of new sailplane.

8.2 SAILPLANE INSPECTION PERIODS

The sailplane inspection periods and range are contained in MAINTENANCE MANUAL.

8.3 SAILPLANE ALTERATIONS OR REPAIRS

It is essential that the responsible airworthiness Authority be contacted prior to any alteration on the sailplane to ensure that the airworthiness of the sailplane is not compromised.

For repairs refer to MAINTENANCE MANUAL.

The sailplane external surfaces should have the write, not getting yellow, Lacquer covering.

On the upper surfaces of wings, tailplane and fuselage no colour markings are allowed (it does not consider the colour markings of the wing tips).

On the control surfaces no markings are allowed to be painted, except producer marks on the rudder which are considered in the mass balance of the rudder.

8.4 GROUND HANDLING, ROAD TRANSPORTATION

TAXIING

The sailplane may be taxied by means of motored vehicle or other device using the front hook. The maximum allowed taxiing speed is 3 kts. The general transportation rules should be observed. During the taxiing the canopy should be locked, and the control stick fastened with the pilot's belts.

NOTE:

Pushing the sailplane on the wing tips or tailplane tips as well as the control surfaces is prohibited.



PARKING ON AIRFIELD

When parking on the airfield the canopy should be locked and protected with a cover.

NOTE:

The non-anchored sailplane cannot be left without the supervision.

ANCHORING

- put the sailplane in such a position that the wind blows from back-side direction,
- put the wing against the wind,
- anchor the sailplane on wing tip, front hook and end of fuselage,
- immobilise the stick by means of pilot's belts.

ROAD TRANSPORTATION

To prepare the sailplane for a transportation:

- check the sailplane to be complete,
- empty the cockpit,
- immobilise the control stick by means of pilot's belts,
- lock the canopy and close the window,
- put the cover on the canopy,
- secure the control systems ends protruding out of the wings to avoid the damages,
- immobilise the ailerons and rudder by means of fixators,
- fix the sailplane components on the trailer on the way that the possibility of damage is excluded (see - storing, the tailplane may be located horizontally).

NOTE:

When the opened trailer is used secure the sailplane with covers.



8.5 CLEANING AND STORING

CLEANING

The sailplane should be washed with water mixed with the normal detergents using the sponge or soft rag. After washing the perviousness of drainage holes should be checked and, if necessary, the structure inside dried (this concerns especially the air brake boxes). For washing the textile elements the special cleaning agents should be used acc. to the recommendation of their producers.

The cockpit should be regularly cleaned with the vacuum cleaner.

NOTE:

Do not use the organic solvents (gasoline, nitro etc.) for canopy perspex cleaning.

STORING

The sailplane should be stored in dry and ventilated room. In case of prolonged storage it is necessary to protect the fittings against a corrosion (e.g. with a grease).

When stored in de-rigged condition its components should be positioned in the way that excludes the possibility of permanent deformations to be got:

- wings - leading edge downwards, supported on the spar roots (near the root rib) and leading edge near the trapeze part end using the soft, fitted stillage,
- fuselage - on wheels, the support under the tail skid. It is also possible to support the fuselage near the cockpit with a soft, fitted stillage.
- tailplane- leading edge downwards; both tips supported on the soft, fitted stillages.

NOTE:

After parking the sailplane on the open air it is necessary to check for the water inside the structure, then dry, clean and ventilate the whole sailplane.



PW-5 "SMYK"
Sailplane Flight Manual

SECTION 9

SUPPLEMENTS

- 9.1 INTRODUCTION
- 9.2 LIST OF INSERTED SUPPLEMENTS



9.1 INTRODUCTION

This Section contains the appropriate supplements necessary for the safe and efficient operation of the sailplane when equipped with various optional systems and equipment not provided with the standard sailplane.

9.2 LIST OF INSERTED SUPPLEMENTS

| Date of insertion | Document No | Title of the inserted supplement |
|-------------------|-------------|----------------------------------|
| (reserved) | (reserved) | High altitude flight |
| (reserved) | (reserved) | Bungee launching |
| (reserved) | (reserved) | Auto - tow launching |